

CARBON & STAINLESS STEEL FLANGES • Dimensions & Weights

Class 150 Flanges to ASME B16.5																
Nominal Size		Dimensions											Weight (kg)			
DN	NPS	Flange OD A mm	Flange Thickness D mm	Bore SOW SW B mm	Raised Face Diam. G mm	Length Thru Hub		Bolt Drilling				RF Stud Bolt Length mm	RF Mach. Bolt Length mm	SOW SW	WN	Blind
						SOW, SW Threaded C mm	W Neck C mm	Circle Diam. K mm	Hole Diam. H mm	Bolets No.	Bolt Diam. In					
15	1/2	88.9	11.2	22.4	35.1	15.8	47.8	60.4	15.7	4	1/2"	60.0	45.0	0.4	0.5	0.4
20	3/4	98.6	12.7	27.7	42.9	15.8	52.3	69.9	15.7	4	1/2"	65.0	50.0	0.6	0.7	0.6
25	1	108.0	14.2	34.5	50.8	17.5	55.6	79.2	15.7	4	1/2"	65.0	55.0	0.8	1.0	0.9
32	1 1/4	117.3	15.7	43.2	63.5	20.6	57.2	88.9	15.7	4	1/2"	70.0	55.0	1.0	1.3	1.2
40	1 1/2	127.0	17.5	49.5	73.2	22.4	62.0	98.6	15.7	4	1/2"	70.0	60.0	1.3	1.7	1.5
50	2	152.4	19.1	62.0	91.9	25.5	63.5	120.7	19.1	4	5/8"	80.0	65.0	2.1	2.6	2.4
65	2 1/2	177.8	22.4	74.7	104.6	28.5	69.9	139.7	19.1	4	5/8"	90.0	75.0	3.3	4.1	3.9
80	3	190.5	23.9	90.7	127.0	30.2	69.9	152.4	19.1	4	5/8"	90.0	75.0	3.9	4.9	4.9
90	3 1/2	215.9	23.9	103.4	139.7	31.8	71.4	177.8	19.1	8	5/8"	90.0	75.0	4.8	6.1	6.2
100	4	228.6	23.9	116.1	157.2	33.3	76.2	190.5	19.1	8	5/8"	90.0	75.0	5.3	6.8	7.0
125	5	254.0	23.9	143.8	185.7	36.6	88.9	215.9	22.4	8	3/4"	90.0	80.0	6.1	8.6	8.6
150	6	279.4	25.4	170.7	215.9	39.6	88.9	241.3	22.4	8	3/4"	100.0	85.0	7.5	10.6	11.3
200	8	342.9	28.4	221.5	269.7	44.5	101.6	298.5	22.4	8	3/4"	110.0	90.0	12.1	17.6	19.6
250	10	406.4	30.2	276.4	323.9	49.3	101.6	362.0	25.4	12	7/8"	115.0	95.0	16.5	24.0	28.8
300	12	482.6	31.8	327.2	381.0	55.6	114.3	431.8	25.4	12	7/8"	120.0	100.0	26.2	36.5	43.2
350	14	533.4	35.1	359.2	412.8	57.2	127.0	476.3	28.4	12	1"	130.0	110.0	34.6	48.4	58.1
400	16	596.9	36.6	410.5	469.9	63.5	127.0	539.8	28.4	16	1"	135.0	115.0	44.8	60.6	76.1
450	18	635.0	39.6	461.8	533.4	68.3	139.7	577.9	31.8	16	1 1/8"	150.0	125.0	48.9	68.3	93.7
500	20	698.5	42.9	513.1	584.2	73.2	144.5	635.0	31.8	20	1 1/8"	160.0	135.0	61.9	84.5	122.0
600	24	812.8	47.8	616.0	692.2	82.6	152.4	749.3	35.1	20	1 1/4"	175.0	145.0	86.9	115.0	185.0

Class 600 Flanges to ASME B16.5																
Nominal Size		Dimensions											Weight (kg)			
DN	NPS	Flange OD A mm	Flange Thickness D mm	Bore SOW SW B mm	Raised Face Diam. G mm	Length Thru Hub		Bolt Drilling				RF Stud Bolt Length mm	RF Mach. Bolt Length mm	SOW SW	WN	Blind
						SOW, SW Threaded C mm	W Neck C mm	Circle Diam. K mm	Hole Diam. H mm	Bolets No.	Bolt Diam. In					
15	1/2	95.3	14.2	22.4	35.1	22.4	52.3	66.5	15.7	4	1/2"	80.0	65.0	0.7	0.9	0.8
20	3/4	117.3	15.7	27.7	42.9	25.4	57.2	82.6	19.1	4	5/8"	90.0	75.0	1.3	1.5	1.3
25	1	124.0	17.5	34.5	50.8	26.9	62.0	88.9	19.1	4	5/8"	90.0	75.0	1.5	1.8	1.6
32	1 1/4	133.4	20.6	43.2	63.5	28.4	66.5	98.6	19.1	4	5/8"	100.0	75.0	2.0	2.5	2.2
40	1 1/2	155.4	22.4	49.5	73.2	31.8	69.9	114.3	22.4	4	3/4"	105.0	75.0	3.0	3.5	3.3
50	2	165.1	25.4	62.0	91.9	36.6	73.2	127.0	19.1	8	5/8"	105.0	75.0	3.6	4.4	4.2
65	2 1/2	190.5	28.4	74.7	104.6	41.1	79.2	149.4	22.4	8	3/4"	120.0	75.0	5.3	6.4	6.1
80	3	209.6	31.8	90.7	127.0	46.0	82.6	168.1	22.4	8	3/4"	125.0	75.0	7.0	8.5	8.4
90	3 1/2	228.6	35.1	103.4	139.7	49.3	85.9	184.2	25.4	8	7/8"	140.0	75.0	8.8	10.7	11.0
100	4	273.1	38.1	116.1	157.2	53.8	101.6	215.9	25.4	8	7/8"	145.0	75.0	14.5	17.4	17.3
125	5	330.2	44.5	143.8	185.7	60.5	114.3	266.7	28.4	8	1"	165.0	75.0	24.4	29.2	29.4
150	6	355.6	47.8	170.7	215.9	66.5	117.3	292.1	28.4	12	1"	170.0	75.0	28.7	34.9	36.1
200	8	419.1	55.6	221.5	269.7	76.2	133.4	349.3	31.8	12	1 1/8"	195.0	75.0	43.4	53.9	58.9
250	10	508.0	63.5	276.4	323.9	85.9	152.4	431.8	35.1	16	1 1/4"	215.0	75.0	70.3	86.5	97.5
300	12	558.8	66.5	327.2	381.0	91.9	155.4	489.0	35.1	20	1 1/4"	220.0	75.0	84.2	103.0	124.0
350	14	603.3	69.9	359.2	412.8	93.7	165.1	527.1	38.1	20	1 3/8"	235.0	75.0	98.7	122.0	151.0
400	16	685.8	76.2	410.5	469.9	106.4	177.8	603.3	41.1	20	1 1/2"	255.0	75.0	142.0	170.0	214.0
450	18	743.0	82.6	461.8	533.4	117.3	184.2	654.1	44.5	20	1 5/8"	275.0	75.0	173.0	204.0	272.0
500	20	812.8	88.9	513.1	584.2	127.0	190.5	723.9	44.5	24	1 5/8"	290.0	75.0	220.0	254.0	349.0
600	24	939.8	101.6	616.0	692.2	139.7	203.2	838.2	50.8	24	1 7/8"	330.0	75.0	312.0	358.0	533.0

Class 300 Flanges to ASME B16.5																
Nominal Size		Dimensions											Weight (kg)			
DN	NPS	Flange OD A mm	Flange Thickness D mm	Bore SOW SW B mm	Raised Face Diam. G mm	Length Thru Hub		Bolt Drilling				RF Stud Bolt Length mm	RF Mach. Bolt Length mm	SOW SW	WN	Blind
						SOW, SW Threaded C mm	W Neck C mm	Circle Diam. K mm	Hole Diam. H mm	Bolets No.	Bolt Diam. In					
15	1/2	95.3	14.2	22.4	35.1	22.4	52.3	66.5	15.7	4	1/2"	65.0	55.0	0.6	0.8	0.6
20	3/4	117.3	15.7	27.7	42.9	25.4	57.2	82.6	19.1	4	5/8"	75.0	60.0	1.1	1.3	1.1
25	1	124.0	17.5	34.5	50.8	26.9	62.0	88.9	19.1	4	5/8"	80.0	65.0	1.4	1.5	1.4
32	1 1/4	133.4	19.1	43.2	63.5	26.9	65.0	98.6	19.1	4	5/8"	80.0	65.0	1.7	2.0	1.8
40	1 1/2	155.4	20.6	49.5	73.2	30.2	68.3	114.3	22.4	4	3/4"	90.0	75.0	2.5	2.9	2.7
50	2	165.1	22.4	62.0	91.9	33.3	69.9	127.0	19.1	8	5/8"	90.0	75.0	2.9	3.4	3.2
65	2 1/2	190.5	25.4	74.7	104.6	38.1	76.2	149.4	22.4	8	3/4"	100.0	85.0	4.3	5.2	4.9
80	3	215.9	28.4	90.7	127.0	42.9	79.2	168.1	22.4	8	3/4"	110.0	90.0	5.9	6.9	6.8
90	3 1/2	228.6	30.2	103.4	139.7	44.5	81.0	184.2	22.4	8	3/4"	110.0	95.0	7.3	8.7	8.7
100	4	254.0	31.8	116.1	157.2	47.8	85.9	200.2	22.4	8	3/4"	110.0	95.0	9.6	11.2	11.5
125	5	279.4	35.1	143.8	185.7	50.8	98.6	235.0	22.4	8	3/4"	120.0	100.0	12.3	15.1	15.6
150	6	317.5	36.6	170.7	215.9	52.3	98.6	269.7	22.4	12	3/4"	125.0	105.0	15.6	19.1	20.9
200	8	381.0	41.1	221.5	269.7	62.0	112.3	330.2	25.4	12	7/8"	140.0	110.0	24.2	29.9	34.3
250	10	444.5	47.6	276.4	323.9	66.5	117.3	387.4	28.4	16	1"	155.0	130.0	34.1	42.7	53.3
300	12	520.7	50.8	327.2	381.0	73.2	130.0	450.9	31.8	16	1 1/8"	170.0	145.0	49.8	61.8	78.8
350	14	584.2	53.8	359.2	412.8	76.2	142.7	514.4	31.8	20	1 1/8"	175.0	150.0	69.9	85.8	105.0
400	16	647.7	57.2	410.5	469.9	82.6	146.1	571.5	35.1	20	1 1/4"	190.0	160.0	88.1	106.0	137.0
450	18	711.2	60.5	461.8	533.4	88.9	158.8	626.7	35.1	24	1 1/4"	195.0	170.0	109.0	131.0	175.0
500	20	774.7	63.5	513.1	584.2	95.3	162.1	685.8	35.1	24	1 1/4"	205.0	180.0	134.0	158.0	221.0
600	24	914.4	70.0	616.0	692.2	106.4	168.1	812.8	41.1	24	1 1/2"	230.0	195.0	201.0	230.0	339.0

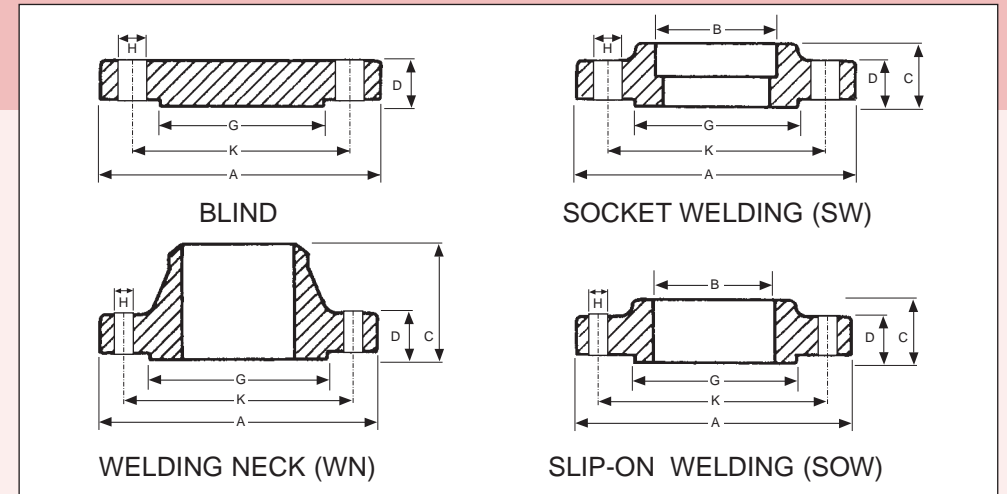

Note 1: All weights are approximate
Note 2: For Class 150, 300 the flange thickness "D" dimension includes approx. 1.5mm for the raised face height. For Class 600, 900, 1500, 2500 the flange thickness does not include the raised face height and approx. 6.4mm must be added to D dimension
Note 3: Bolt length dimensions incorporate the height of the raised face
Note 4: Welding Neck bore is derived from the pipe schedule

CARBON & STAINLESS STEEL FLANGES • Dimensions & Weights

Class 900 Flanges to ASME B16.5															
Nominal Size		Dimensions										Weight (kg)			
		Flange OD A mm	Flange Thickness D mm	Bore SOW SW B mm	Raised Face Diam. G mm	Length Thru Hub		Bolt Drilling				RF Stud Bolt Length mm	SOW SW	WN	Blind
SOW, SW Threaded C mm	W Neck C mm					Circle Diam. K mm	Hole Diam. H mm	Bolts No.	Bolt Diam. In						
15	1/2	120.7	22.4	22.4	35.1	31.8	60.5	82.6	22.4	4	3/4"	105.0	1.8	1.9	1.8
20	3/4	130.0	25.4	27.7	42.9	35.1	70.0	88.9	22.4	4	3/4"	115.0	2.4	2.6	2.4
25	1	149.4	28.4	34.5	50.8	41.1	73.2	101.6	25.4	4	7/8"	125.0	3.6	3.7	3.6
32	1 1/4	158.8	28.4	43.2	63.5	41.1	73.2	111.3	25.4	4	7/8"	125.0	4.0	4.3	4.1
40	1 1/2	177.8	31.8	49.5	73.2	44.5	82.6	124.0	28.4	4	1"	140.0	5.5	5.9	5.8
50	2	215.9	38.1	62.0	91.9	57.2	101.6	165.1	25.4	8	7/8"	145.0	10.2	10.8	10.1
65	2 1/2	244.3	41.1	74.7	104.6	63.5	104.6	190.5	28.4	8	1"	160.0	13.9	15.0	14.0
80	3	241.3	38.1	90.7	127.0	53.8	101.6	190.5	25.4	8	7/8"	145.0	11.6	13.7	13.1
100	4	292.1	44.5	116.1	157.2	69.9	114.3	235.0	31.8	8	1 1/8"	170.0	19.7	22.5	26.9
125	5	349.3	50.8	143.8	185.7	79.2	127.0	279.4	35.1	8	1 1/4"	190.0	31.9	37.4	36.5
150	6	381.0	55.6	170.7	215.9	85.9	139.7	317.5	31.8	12	1 1/8"	195.0	41.1	47.7	47.4
200	8	469.9	63.5	221.5	269.7	101.6	162.1	393.7	38.1	12	1 3/8"	220.0	70.7	81.3	82.5
250	10	546.1	69.9	276.4	323.9	108.0	184.2	469.9	38.1	16	1 3/8"	235.0	101.0	119.0	122.0
300	12	609.6	79.2	327.2	381.0	117.3	200.2	533.4	38.1	20	1 3/8"	255.0	133.0	157.0	173.0
350	14	641.4	85.6	359.2	412.8	130.0	212.9	558.8	41.1	20	1 1/2"	275.0	153.0	180.0	206.0
400	16	704.9	88.9	410.5	469.9	133.4	215.9	616.0	44.5	20	1 5/8"	285.0	185.0	217.0	259.0
450	18	787.4	101.6	461.8	533.4	152.4	228.6	685.8	50.8	20	1 7/8"	325.0	258.0	292.0	367.0
500	20	857.3	108.0	513.1	584.2	158.8	247.7	749.3	53.8	20	2"	345.0	317.0	362.0	463.0
600	24	1041.4	139.7	616.0	692.2	203.2	292.1	901.7	66.5	20	2 1/2"	435.0	606.0	665.0	876.0

Class 1500 Flanges to ASME B16.5															
Nominal Size		Dimensions										Weight (kg)			
		Flange OD A mm	Flange Thickness D mm	Bore SOW SW B mm	Raised Face Diam. G mm	Length Thru Hub		Bolt Drilling				RF Stud Bolt Length mm	SOW SW	WN	Blind
SOW, SW Threaded C mm	W Neck C mm					Circle Diam. K mm	Hole Diam. H mm	Bolts No.	Bolt Diam. In						
15	1/2	120.7	22.4	22.4	35.1	31.8	60.5	82.6	22.4	4	3/4"	105.0	1.8	1.9	1.8
20	3/4	130.0	25.4	27.7	42.9	35.1	69.9	88.9	22.4	4	3/4"	115.0	2.4	2.6	2.4
25	1	149.4	28.4	34.5	50.8	41.1	73.2	101.6	25.4	4	7/8"	125.0	3.6	3.7	3.6
32	1 1/4	158.8	28.4	43.2	63.5	41.1	73.2	111.3	25.4	4	7/8"	125.0	4.0	4.3	4.1
40	1 1/2	177.8	31.8	49.5	73.2	44.5	82.6	124.0	28.4	4	1"	140.0	5.5	5.9	5.8
50	2	215.9	38.1	62.0	91.9	57.2	101.6	165.1	25.4	8	7/8"	145.0	10.2	10.8	10.1
65	2 1/2	244.3	41.1	74.7	104.6	63.5	104.6	190.5	28.4	8	1"	160.0	13.9	15.0	14.0
80	3	266.7	47.8	90.7	127.0	53.8	117.3	203.2	31.8	8	1 1/8"	180.0	19.9	19.1	19.1
100	4	311.2	53.8	116.1	157.2	69.9	124.0	241.3	35.1	8	1 1/4"	195.0	29.9	29.9	29.9
125	5	374.7	73.2	143.8	185.7	79.2	155.4	292.1	41.1	8	1 1/2"	250.0	55.4	58.4	58.4
150	6	393.7	82.6	170.7	215.9	85.9	171.5	317.5	38.1	12	1 3/8"	260.0	68.4	71.8	71.8
200	8	482.6	91.9	221.5	269.7	101.6	212.9	393.7	44.5	12	1 5/8"	290.0	117.0	122.0	122.0
250	10	584.2	108.0	276.4	323.9	108.0	254.0	482.6	50.8	12	1 7/8"	335.0	194.0	210.0	210.0
300	12	673.1	124.0	327.2	381.0	117.3	282.4	571.5	53.8	16	2"	375.0	288.0	316.0	316.0
350	14	749.3	133.4	359.2	412.8	130.0	298.5	635.0	60.4	16	2 1/4"	405.0	380.0	420.0	420.0
400	16	825.5	146.1	410.5	469.9	133.4	311.2	704.9	66.5	16	2 1/2"	445.0	485.0	558.0	558.0
450	18	914.4	162.1	461.8	533.4	152.4	327.2	774.7	73.2	16	2 3/4"	495.0	644.0	760.0	760.0
500	20	984.3	177.8	513.1	584.2	158.8	355.6	831.9	79.2	16	3.0	540.0	775.0	965.0	965.0
600	24	1168.4	203.2	616.0	692.2	203.2	406.4	990.6	91.9	16	3 1/2"	615.0	1232.0	1558.0	1558.0

Class 2500 Flanges to ASME B16.5														
Nominal Size		Dimensions										Weight (kg)		
		Flange OD A mm	Flange Thickness D mm	Raised Face Diam. G mm	Length Thru Hub		Bolt Drilling				RF Stud Bolt Length mm	WN	Blind	
SOW, SW Threaded C mm	W Neck C mm				Circle Diam. K mm	Hole Diam. H mm	Bolts No.	Bolt Diam. In						
15	1/2	133.4	30.2	35.1	39.6	73.2	88.9	22.4	4	3/4"	125.0	3.1	3.0	3.0
20	3/4	139.7	31.8	42.9	42.9	79.2	95.3	22.4	4	3/4"	125.0	3.7	3.5	3.5
25	1	158.8	35.1	50.8	47.8	88.9	108.0	25.4	4	7/8"	140.0	5.2	5.0	5.0
32	1 1/4	184.2	38.1	63.5	52.3	95.3	130.0	28.4	4	1"	150.0	7.7	7.4	7.4
40	1 1/2	203.2	44.5	73.2	60.5	111.3	146.1	31.8	4	1 1/8"	170.0	10.9	10.4	10.4
50	2	235.0	50.8	91.9	69.9	127.0	171.5	28.4	8	1"	175.0	16.2	15.6	15.6
65	2 1/2	266.7	57.2	104.6	79.2	142.7	196.9	31.8	8	1 1/8"	195.0	23.7	22.6	22.6
80	3	304.8	66.5	127.0	168.1	228.6	228.6	35.1	8	1 1/4"	220.0	36.2	34.8	34.8
100	4	355.6	76.2	157.2	190.5	273.1	273.1	41.1	8	1 1/2"	255.0	55.3	53.9	53.9
125	5	419.1	91.9	185.7	228.6	323.9	323.9	47.8	8	1 3/4"	300.0	92.5	90.8	90.8
150	6	482.6	108.0	215.9	273.1	368.3	368.3	53.8	8	2"	345.0	143.0	141.0	141.0
200	8	552.5	127.0	269.7	317.5	438.2	438.2	53.8	12	2"	380.0	215.0	214.0	214.0
250	10	673.1	165.1	323.9	419.1	539.8	539.8	66.5	12	2 1/2"	485.0	406.0	411.0	411.0
300	12	762.0	184.2	381.0	463.6	619.3	619.3	73.2	16	2 3/4"	540.0	572.0	592.0	592.0

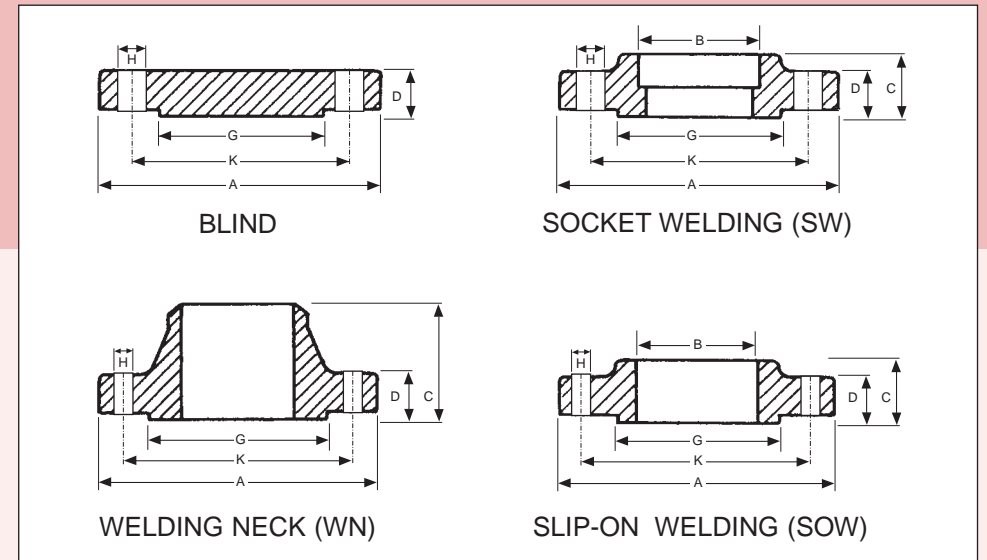

Note 1: All weights are approximate
Note 2: For Class 150, 300 the flange thickness "D" dimension includes approx. 1.5mm for the raised face height
 For Class 600, 900, 1500, 2500 the flange thickness does not include the raised face height and approx. 6.4mm must be added to D dimension
Note 3: Bolt length dimensions incorporate the height of the raised face
Note 4: Welding Neck bore is derived from the pipe schedule

CARBON & STAINLESS STEEL FLANGES • Dimensions & Weights

Table D Flanges to AS 2129

Nominal Size	Dimensions(mm)							Weight (kg)	
	DN	OD A	Thickness D	Raised Face Diam G	Drilling		Bolt Size & Thread	SOW	Blind
					Bolt Circle Diam K	Bolt Hole Diam H			
15	95	*5	47	67	14	4	M12	0.6	0.6
20	100	*5	53	73	14	4	M12	0.7	0.7
25	115	*5	65	83	14	4	M12	0.9	1.0
32	120	*6	67	87	14	4	M12	0.9	1.1
40	135	*6	78	98	14	4	M12	1.2	1.4
50	150	*8	90	114	18	4	M16	1.4	1.7
65	165	*8	103	127	18	4	M16	1.6	2.1
80	185	*10	122	146	18	4	M16	2.0	2.7
90	205	*10	141	165	18	4	M16	2.2	3.2
100	215	*10	154	178	18	4	M16	2.5	3.6
125	255	13	186	210	18	8	M16	3.3	4.9
150	280	13	211	135	18	8	M16	4.0	6.1
200	335	13	268	292	18	8	M16	5.0	8.8
250	405	16	328	256	22	8	M20	8.7	15.8
300	455	19	378	406	22	12	M20	11.3	23.6
350	525	22	438	470	26	12	M24	19.6	38.6
400	580	22	489	521	26	12	M24	22.3	44.9
450	640	25	532	584	26	12	M24	29.0	63.0
500	705	29	609	641	26	16	M24	39.9	86.0
550	760	29	637	699	30	16	M27	50.0	107.0
600	825	32	720	756	30	16	M27	58.0	125.0
700	910	35	809	845	30	20	M27		
750	995	41	888	927	33	20	M30		
800	1060	41	942	984	36	20	M33		
850	1090	44	974	1016	36	20	M33		
900	1175	48	1050	1092	36	24	M33		
1000	1255	51	1133	1175	36	24	M33		
1200	1490	60	1368	1410	36	32	M33		

Table E Flanges to AS 2129

Nominal Size	Dimensions(mm)							Weight (kg)	
	DN	OD A	Thickness D	Raised Face Diam G	Drilling		Bolt Size & Thread	SOW	Blind
					Bolt Circle Diam K	Bolt Hole Diam H			
15	95	*6	47	67	14	4	M12	0.6	0.7
20	100	*6	53	73	14	4	M12	0.7	0.8
25	115	*7	63	83	14	4	M12	0.9	1.0
32	120	*8	67	87	14	4	M12	1.0	1.1
40	135	*9	78	98	14	4	M12	1.2	1.4
50	150	*10	90	114	18	4	M16	1.4	1.7
65	165	*10	103	127	18	4	M16	1.6	2.1
80	185	*11	122	146	18	4	M16	2.0	2.7
90	205	12	141	165	18	8	M16		
100	215	13	154	178	18	8	M16	2.5	3.6
125	255	14	186	210	18	8	M16	3.3	5.5
150	280	17	207	235	22	8	M20	5.0	8.3
200	335	19	264	292	22	8	M20	7.1	12.9
250	405	22	328	356	22	12	M20	11.4	21.9
300	455	25	374	406	26	12	M24	15.1	31.8
350	525	29	438	470	26	12	M24	25.3	47.6
400	580	32	489	521	26	12	M24	31.3	66.0
450	640	35	552	584	26	16	M24	40.8	87.0
500	705	38	609	641	26	16	M24	53.0	114.0
550	760	44	663	699	30	16	M27		
600	825	48	717	756	33	16	M30	85.0	195.0
700	910	51	806	845	33	20	M30		
750	995	54	885	927	36	20	M33		
800	1060	54	942	984	36	20	M33		
850	1090	57	974	1016	36	20	M33		
900	1175	64	1050	1092	36	24	M33		
1000	1255	67	1130	1175	39	24	M36		
1200	1490	79	1365	1410	39	32	M36		

Table F Flanges to AS 2129

Nominal Size	Dimensions(mm)							Weight (kg)	
	DN	Flange OD A	Flange Thickness D	Raised Face Diam G	Drilling		Bolt Size & Thread	SOW	Blind
					Bolt Circle Diam K	Bolt Hole Diam H			
15	95	10	47	67	14	4	M12	0.6	0.7
20	100	10	53	73	14	4	M12	0.7	0.8
25	120	10	63	87	18	4	M16	0.9	1.0
32	135	13	74	98	18	4	M16	1.1	1.3
40	140	13	81	105	18	4	M16	1.2	1.4
50	165	16	103	127	18	4	M16	2.2	2.6
65	185	16	122	146	18	4	M16	2.5	3.0
80	205	16	141	165	18	8	M16	3.0	3.8
90	215	19	154	178	18	8	M16		
100	230	19	167	191	18	8	M16	4.3	5.9
125	280	22	207	235	22	8	M20	7.4	10.1
150	305	22	232	260	22	12	M20	8.1	11.9
200	370	35	296	324	22	12	M20	12.7	20.3
250	430	29	349	381	26	12	M24	18.1	31.4
300	490	32	406	438	26	16	M24	23.9	44.7
350	550	35	459	495	30	16	M27	35.3	63.0
400	610	41	516	552	30	20	M27	47.6	90.0
450	675	44	571	610	33	20	M30	62.0	120.0
500	735	51	634	673	33	24	M30	80.0	162.0
550	785	54	685	724	33	24	M30		
600	850	57	739	781	36	24	M33	112.0	
700	935	60	815	857	36	24	M33		
750	1015	67	898	940	36	28	M33		
800	1060	68	942	984	36	28	M33		
850	1090	70	974	1016	36	32	M33		
900	1185	76	1060	1105	39	32	M36		
1000	1275	83	1149	1194	39	36	M36		
1200	1530	95	1385	1441	42	40	M39		

Table H Flanges to AS 2129

Nominal Size	Dimensions(mm)							Weight (kg)	
	DN	Flange OD A	Flange Thickness D	Raised Face Diam G	Drilling		Bolt Size & Thread	SOW	Blind
					Bolt Circle Diam K	Bolt Hole Diam H			
15	115	13	57	83	18	4	M16	0.8	1.0
20	115	13	57	83	18	4	M16	0.9	1.0
25	120	14	64	87	18	4	M16	1.1	1.2
32	135	17	76	98	18	4	M16	1.5	1.8
40	140	17	83	105	18	4	M16	1.7	2.0
50	165	19	102	127	18	4	M16	2.6	3.1
65	185	19	114	146	18	8	M16	3.1	3.8
80	205	22	127	165	18	8	M16	4.3	5.4
90	215	22	140	178	18	8	M16		
100	230	25	152	191	18	8	M16	5.8	7.9
125	280	29	178	235	22	8	M20	9.9	12.6
150	305	29	210	260	22	12	M20	10.8	15.4
200	370	32	260	324	22	12	M20	18.3	28.2
250	430	35	311	381	26	12	M24	22.1	38.0
300	490	41	362	438	26	16	M24	31.0	58.0
350	550	48	419	495	30	16	M27	47.7	85.0
400	610	54	483	552	30	20	M27	62.0	118.0
450	675	60	533	610	33	20	M30	105.0	196.0
500	735	67	597	673	33	24	M30		
550	785	70	648	724	33	24	M30		
600	850	76	699	781	36	24	M33		

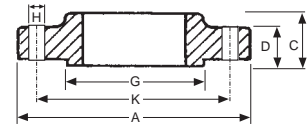

SLIP-ON WELDING (SOW)

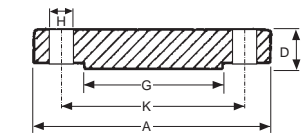

BLIND

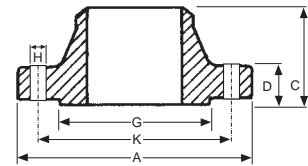

WELDING NECK (WN)

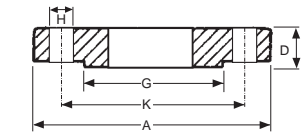

PLATE

Note 1: All weights are approximate
Note 2: A diametrical clearance of 4mm maximum applies to pipe or tube OD for plate flanges
Note 3: The flange thickness "D" dimension included the raised face height
Note 4: Welding Neck bore is derived from the pipe schedule

